

Specifications Guide

UV Ballasts

UVB80W-800-24VDC

Lamp Type /Catalog #	Manufacturer	# of Lamps	Power (W)	Current (mA)
GHO660T5L/4P	Light Source	1	62	800

Ballast Specifications

Ballast type:	Program Start (PS)
Number of lamps:	1
Normal input voltage:	24VDC, +/-10%
Input current:	3.4A
Input power:	80W @ full load
Operating frequency:	> 35kHz
Approvals:	UL/cUL Listed, Class "P"

Efficiency:	> 90%
Ballast shut down/protection:	EOL/OC
Ambient temperature:	0-40°C
Case maximum temperature:	75°C
Sound rating:	"A"
Weight:	2.55 lbs

Wiring Diagram and Dimensions

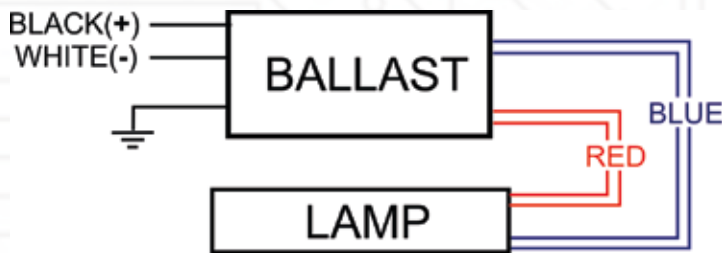

Dimensions: 9.47" (L) x 2.29" (W) x 1.67" (H)

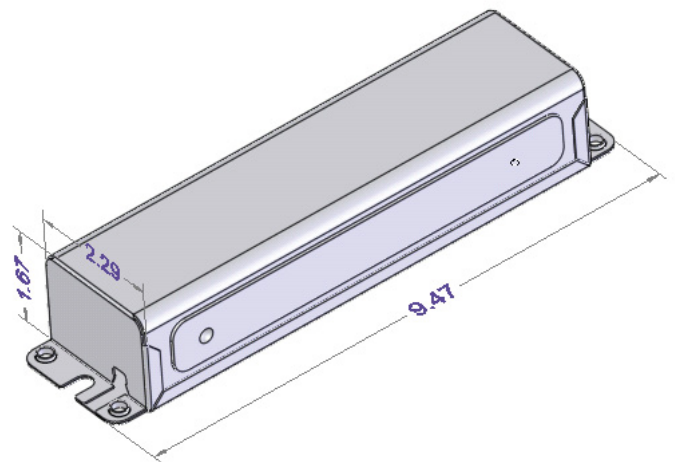

Allanson
LIGHTING TECHNOLOGIES

