

ALLANSON LIGHTING TECHNOLOGIES INC

SPECIFICATION SHEET FOR

UVB BALLAST CATALOG#: UVB164T6-2100-MV-PDP

1. Lamp type

AMALGAM LAMP

Lamp type/Cata #	Manufacture	Power (W)	Current (A)
NNI 300/147XL	Heraeus Noblelight	325	2.1
TUV 325W XPT	Philips	325	2.1
GIA1570T6LCA/HO/4C	First Light	320	2.2
GPHHVA1554T6L/4	Light Sources	320	2.1

2. Electrical

Ballast type	Program start (PS)
Number of lamps	1
Normal input voltage:	120-240V, +/- 10%, 50-60 Hz
Input current	2.75A(120V)/1.40A(240V)
Input power:	330W@ full load
Operating frequency	>25 kHz
Lamp current crest factor	1.7 or less
Power Factor:	>95%
Efficiency:	>90%
Protection:	EOL/OC
Low inrush current	5 A
Dimming range	100% to 50% (Output current)
Dimming control	0-10VDC
Approvals	UL R/C, Class "P", Indoor, Type 1
Sound rating	"A"

3. Wiring Diagram

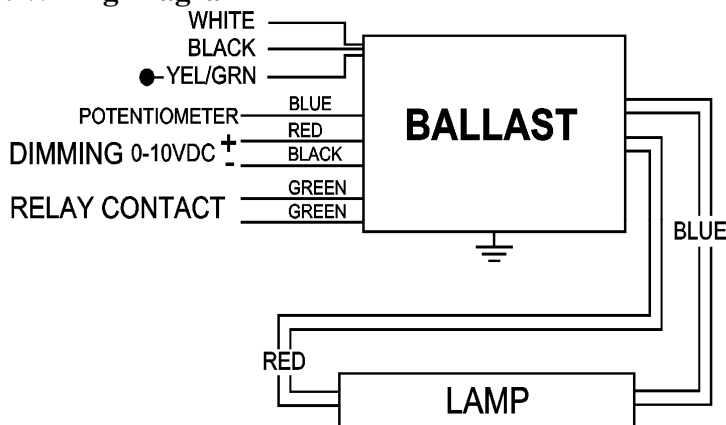

4. Mechanical Data

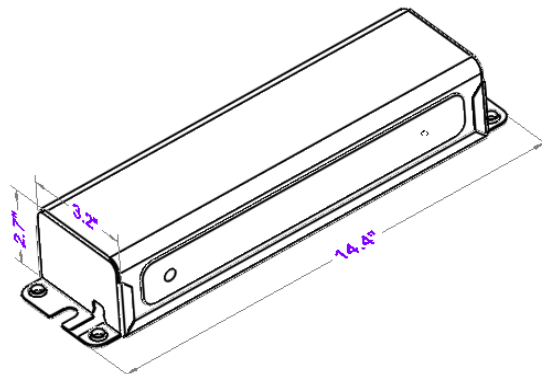

5. Features

Dimming and control (external DC voltage)

Red, and blue diagnostic LEDs, and dry contact for sensing, and alarming both ballast/lamp operation, and failure.