

OMNI® UNIVERSAL ELECTRONIC IGNITORS

DESCRIPTION:

Unlike competitive units, Allanson's OMNI® Electronic Ignitors are truly universal and will mount onto any manufacturers' existing electronic ignitor mounting plate - resulting in a perfect fit, every time. With up to three different models to choose from, installation on any application will be effortless. Each OMNI® Ignitor comes complete with required hardware, providing even more convenience, making your service calls quick and easy. The product is also available in a service kit.

FEATURES:

- Universal application
- Eliminates need for other mounting plates
- History of excellent operation under brownout conditions
- Quick & easy to change
- Minimize inventory
- Energy efficient
- Low operating temperature
- Ships complete with required hardware



Storage Temperature (°C):	-40 to +80
Operating Temperature (°C):	-30 to +40
Operating Relative Humidity (%):	90
Loading Air Gap (inches)	1/16 - 3/16

TECHNICAL SPECIFICATION:

MODEL	DESCRIPTION	Pri A	Sec KVpk	mA	V A	LENGTH (in)	DEPTH (in)	HEIGHT (in)
2270U	12 Volt DC, 14 kVrms Secondary, Mid Point Ground	0.5	17.5	20	-	4.06	4.92	2.91
2275U	120 Volt, 50/60 Hz, Mid Point Ground	-		45	87			
2280U	240 Volt, 50/60 Hz, Mid Point Ground	-		28	87			

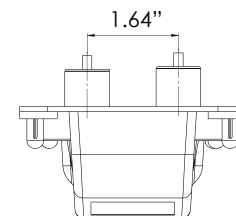
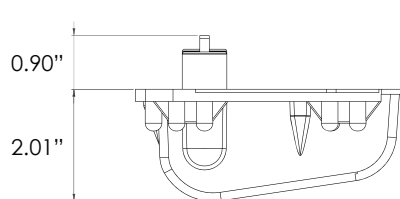
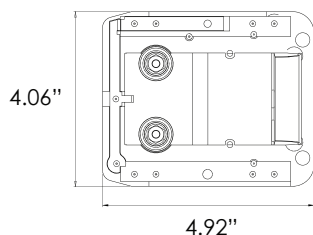

SERVICE KIT:

2275-KIT1 and 2275-KITCAN

Electronic Ignition Transformer Service Kit

- 2 OMNI® Universal Ignitors
- Selection of mounting plates
- Variety of contact terminals
- Tool box

**Contact Customer Service For Customized Kits*



	2275U OMNI®	2600 AERO	2601 BECKETT S	2602 WAYNE HI SPEED M/MH	2603 WAYNE E	2604 BECKETT A, AF, AFG	2605 CARLIN 99, 100, 101, M/ser	2609 CARLIN 17.5 FR, 200, 201, 500, 501 CRD	2612 GRIMSBY	2614 BROCK	54-740 Universal Contact Kit
2275-KIT1	2	1	1	1	1	1	1			1	
2275-KITCAN	2	2				2	1				1

CROSS REFERENCE CHART:

MANUFACTURER (Burner & Transformer)	ALLANSON INTERNATIONAL		BECKETT	CARLIN	FRANCE	SID HARVEY	WEBSTER
AERO	2275-456	2275U	51828U	41000-SO-AR	10SAY-56	T87E	3-24AB-AER
BECKETT A, AF, AFG	2275-628G	2275U	51771U	41000-SO-BK1	10SAY-04	T92E	3-28AB-BAFR
BECKETT AF II	2275-658	2275U	51805U	-	10SAYL-70	T97E	3-32AB-BAF
BECKETT S	2275-605	2275U	51824U	41000-SO-BK2	10SAY-05	T90E	3-28AB-BS
CARLIN 17.5, 200, 201, 500, 501, CRD	2275-629	2275U	51840U	41000-SO-SC	10SAY-16	T95E	313-24AB81
CARLIN 99, 100, 101, CRD	2275-630	2275U	51826U	41000-SO-CAS	10SAY-15	T94E	313-28AB85
CARLIN 601 & Up	2275-633	2275U	51880U	41000-SO-LC	-	-	12-8AB7
WAYNE Hi Speed M/MH	2275-619	2275U	51825U	41000-SO-WA3	10SAY-03	T93E	313-28AB91
WAYNE E	2275-620	2275U	51827U	41000-SO-WA2	10SAY-30	T88E	313-25AB78
WAYNE HS	2275-647	2275U	51836U	41000-SO-WA1	10SAY-31	T89-10E	313-28AB205
WEIL MCLAIN	2275-653	2275U	51837U	41000-SO-WM	10SAY-32	T96E	-
IGNITOR KIT	2275-KIT	2275U	51835	41000-SO-KIT	10SAY-KIT	T97K	-

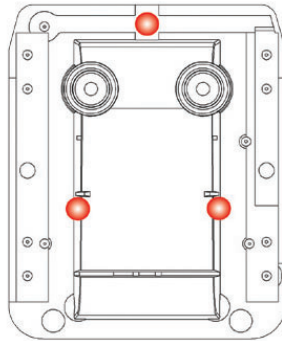
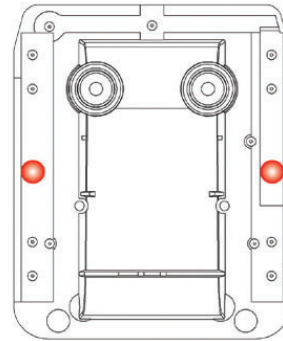
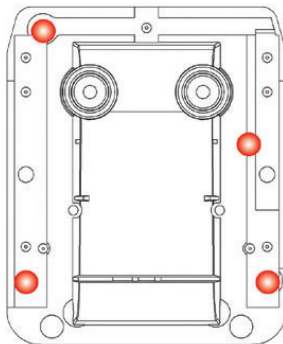
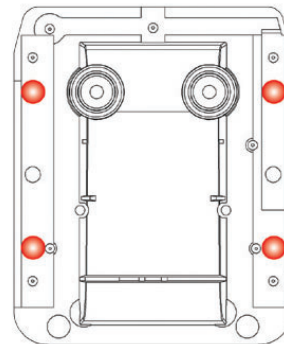
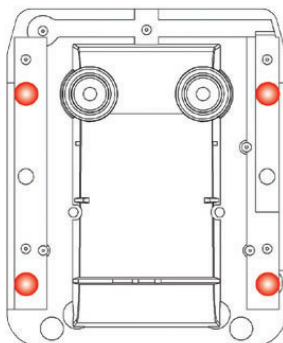
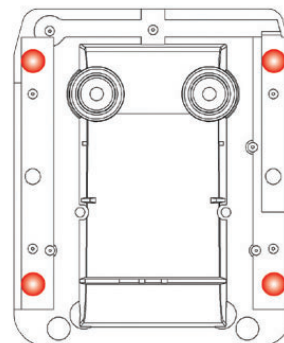

MOUNTING PLATE CONFIGURATION:

 **Allanson****Beckett****Carlin****France****Wayne****Webster**



ELECTRONIC IGNITOR INSTRUCTION MANUAL - TYPE 2270U / 2275U / 2280U

This instruction manual provides you with application information on the OMNI™ Electronic Ignitor. Allanson's electronic ignitors are designed for **intermittent duty (constant)** and/or **interrupted duty** - providing the most reliable ignition source for gas and oil.

Absolute Minimum Readings:

Model #	2270	2275	2280
Input Supply Voltage (V):	11-14.5	108-132	216-252
Input Current (A):	2.5		
Input Supply Frequency (Hz):		50/60	50/60
Primary Voltage - Amperes (VA):		87	87
Secondary Voltage (kV peak):	17.5	17.5	17.5
Secondary Frequency (kHz):	>18	>20	>20
Secondary Short Circuit Current (mA):	20	45	28
Storage Temperature (°C):	-40 to +80	-40 to +80	-40 to +80
Operating Temperature (°C):	-30 to +40	-30 to +40	-30 to +40
Operating Relative Humidity (%):	90	90	90
Loading Air Gap (inches):	1/16 - 1/8	1/16 - 3/16	1/16 - 3/16

Mechanical Specifications:

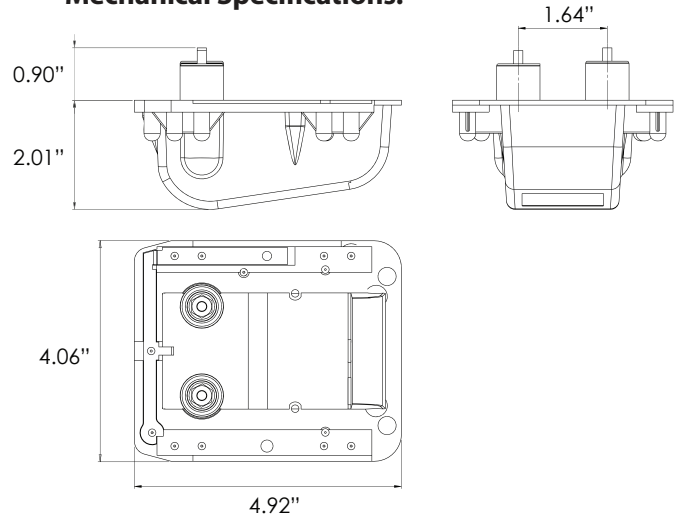

Installation:

1. Before installation, inspect the case and the porcelain bushings for possible damage during transportation and handling. Do not use the product if the secondary bushings are chipped and/or cracked.
2. Choose the correct base plate from the kit (if provided) to fit the burner. Route the primary lead wires to the appropriate lead exit on the base plate and fasten the electronic ignitor to this plate with the three self-tapping screws provided.
3. Install the electronic ignitor assembly on the burner and route the primary leads to the junction box for connection. **Connect the black lead to the negative terminal (-) and the red lead to the positive terminal (+) of the supplies.** (Reversing the lead connection will result in the unit not operating properly). Use only UL Listed and CSA approved wire nuts.

Maintenance:

The OMNI® Electronic Ignitor has no moving parts. The only maintenance required is the cleaning of the porcelain bushings with a soft cloth during the annual furnace inspection.

Testing:

WARNING

This procedure is to be carried out by qualified personnel ONLY.

The voltages and currents available can cause serious injury and/or death. Extreme caution is to be used to avoid contact with the primary live leads. Do not allow any parts of your body to come closer than 5 inches to the energized secondary terminals or parts of the secondary circuit. Ensure the mid-point of the transformer is grounded before energizing the primary.

The OMNI® Electronic Ignitor can be tested as follows to ensure that it is operating properly.

Chek-Mate™ (Allanson's Ignitor/Transformer tester). Use it to touch any brand of ignitor/transformer. Simply touch the high voltage spheres to the high voltage contacts. If the green LED lights up, the unit is performing well.

Short Circuit Current Test. Connect a true RMS high frequency milliammeter to the output terminals. Energize the primary with 12 Volts DC (2270U) / 120 Volts (2275U) / 240 Volts (2280U) at 50/60 Hz. The reading on the milliammeter should be within 10% of the rated.

Open Circuit Test. For this test you need an oscilloscope and a high voltage oscilloscope probe. Connect the high voltage probe from one secondary to the ground terminal (screw in front and between the high voltage bushings). Measure the peak of the wave form on the oscilloscope. Repeat the procedure for the opposite high voltage terminal. The sum of the two readings should be within 10% of the name plate rating.

Field Testing. Connect the electronic ignitor grounding terminal to a good ground. Connect the primary leads of the electronic ignitor to 12 Volts DC (2270U) / 120 Volts (2275U) / 240 Volts (2280U). Energize the primary. Holding the handle of a well insulated screw driver, touch one part of the shaft of the screw driver to one high voltage terminal. Pivot on this terminal until you draw an arc from the opposite terminal. Gradually increase the air gap and notice the distance at which the arc is extinguished. The minimum distance should be 1/2".

For more information please visit us at allanson.com or contact us at cservice@allanson.com.

CANADA: 83 Commerce Valley Drive East, Markham, Ontario L3T 7T3 | T: 1.800.661.7251 | Fax: 416.752.6717

USA: 181 Cooper Ave., Suite 112, Tonawanda, NY 14150 | T: 1.631.293.3880 | Fax: 1.631.293.3470