

14kV / 12mA High Voltage Power Supply for Electrostatic Air Cleaner

Specifications and operating manual

Cat # AHVPS714-12-MV-PCB

1. Overview

The 14kVDC/12mA HV power supply is an OEM product and comes without AC power ON/OFF switch and safety interlocks. It is system integrator responsibility to assure that all national, state and local electrical safety codes are followed.

1.1 Principle of operation

The block diagram of HV Power Supply is shown in Fig. 1

The HV Power supply has built in universal input, power factor corrected AC/DC power converter, which produces 450VDC for the resonant DC/DC HV power converter. The Resonant Power Converter drives the HV step up transformer, which delivers up to 1.5kV RMS to the HV multiplier. The 4 stage HV multiplier produces up to 14kVDC at the output (Ionizer) and 7kVDC at the output of second stage (collector).

This PS has capabilities to deliver up to 12mA DC current at 14KVDC to 4 X 24" Linear cells. Max input current on 120V is 2A

The resonant power converter is over voltage, over current, overpower protected including continuous output short circuit condition.

Operating HV and output current limit are set manually however Intelligent Controller has the capability to perform the following functions:

1. Monitors HV and output current
2. Maintain the best performance and minimize load cell arcing
3. Reports HV converter status using LED Lamps and optional serial messages on RS-485 port or Modbus.

Operating HV, Current, number of hours of operation, error codes can be monitored on optional RS-485 output or Modbus output terminals.

Additional HV and current can be monitored on scaled down analog output.

I Monitor – 100mV per 1mA

V monitor – 100mV per 1KV

4. Keeps track of operating hours

5. Connect to Remote LED diagnostic PCB.

Status LED functionality and simplified flowchart are shown in Appendix A.

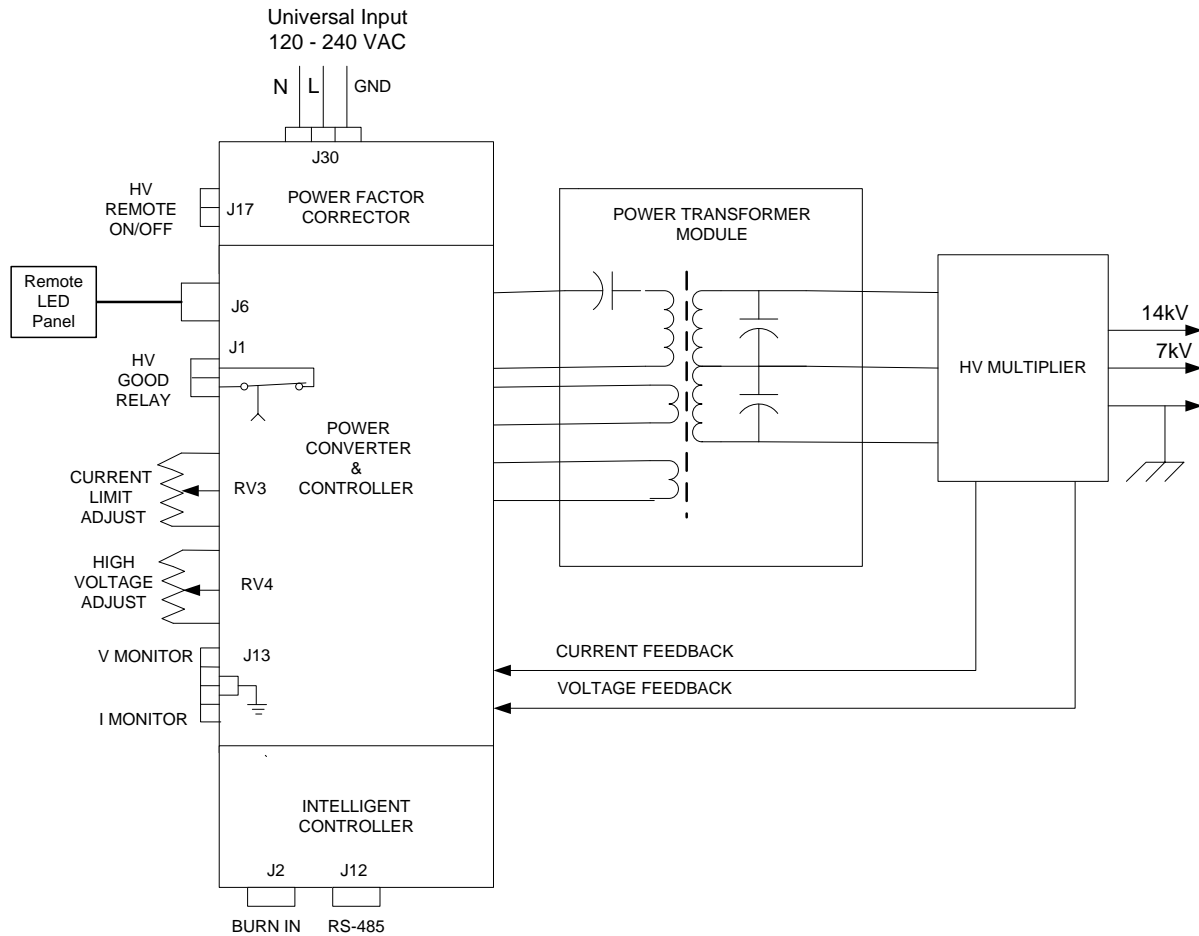

Fig.1 HV Power Supply Block Diagram

2.0 Modes of operation

Standby Mode (HV converter is OFF, Microcontroller – MCU is ON)

HV Converter ON Mode

Voltage Source Mode
Current Source Mode
Burn-in Mode

2.1 Standby Mode

2.2 In Standby Mode the main supply is On (J30) and powers microcontroller (MCU) circuit. The MCU reports the power supply status on serial port. J12 open (Run signal is not received) -- **Standby Mode**

2.2 HV Converter ON Mode

Voltage source Mode

In Voltage Source Mode the HVPS maintains the preset voltage while current is determined by the load. If current does not exceed the max limit of 12mA the HVPS will maintain the preset HV.

Voltage mode example settings: The HV was set to 12kV and current limit was set to the maximum value of 12mA. After connecting the clean load cell, the HVPS was operating at 12kV with current floating around 12mA. With the same settings and dirty load cell connected, the HVPS was still operating at 12kV, but the load current dropped to 10mA.

Current Source Mode

In Current Source Mode the HVPS maintains the preset current while voltage is determined by the load. If output voltage does not exceed the max limit of 14kV the HVPS will maintain the preset current.

Current Mode example settings. The current limit was set to 12mA and HV to 14kV. After connecting the clean load cell, the HVPS was operating at 12mA current and HV floating around 12kV. With the same settings and dirty load cell connected, the HVPS was operating with 12mA current, but HV increased to 12.5kV to maintain 12mA current.

Burn-In Mode.

The Burn-in Mode is invoked by the pushbutton momentary switch SW1 located on the PCB or by shorting terminals of connector J2 located next to the pushbutton switch or terminating two wires to external momentary push button.

In normal operation the HVPS is exposed to occasional overload conditions caused by arcing in the load cells. The HVPS monitors the rate and duration of overload conditions and shut down if overload condition persists.

New load cells may be contaminated with remnants of machining process and may cause excessively high rate of arcing for first few hours of operation which may cause the HVPS to shut down prematurely. To prevent this unnecessary shutdown the Burn In mode was introduced.

When Burn In mode is activated (by pressing the Burn In ON/OFF switch), red LED will be blinking until burning process is completed or terminated, the HVPS will not shut down in response to persistent overload condition for 3 hours period.

In Burn-In mode the protection algorithm, which monitors rate and duration of overloads and shuts down the HVPS if overload persists is suspended for 3 hours.

The Burn In mode can be terminated before 3-hour timer expires by pressing the Burn In ON/OFF switch.

During Burn In cycle the display alternates between standard Voltage and Current readings and Burn In cycle message.

3.0 Installation and safety

The HV Power Supply must be mounted indoors, protected from weather elements, in a location easily accessible by operating service personnel.

The HV Power Supply is equipped with universal input; power factor corrected (PFC) AC/DC power supply and can operate from 120VAC or 240VAC power lines.

The maximum current draw is 0.85 Amp from 120 VAC line and 0.42 Amp from 240VAC line. Use these numbers to select proper wire gage as per applicable standards.

The connection diagram of HV Power Supply is shown in Fig.2 All connections are made to terminals on the Main Board.

The HV Multiplier has two outputs:

Ionizing Voltage – Labeled as 14kVDC

Collector Voltage – Labeled as 7kVDC

The HV and current adjustment trim pots, Dry Contact (J17) terminal block, AC power input (J30), HV Good Relay (J1) and RS-485 serial port (J12) are located at the outside part of the Main Board.

Status LEDs are placed on the remote panel connected to RJ45 type connector (J6).

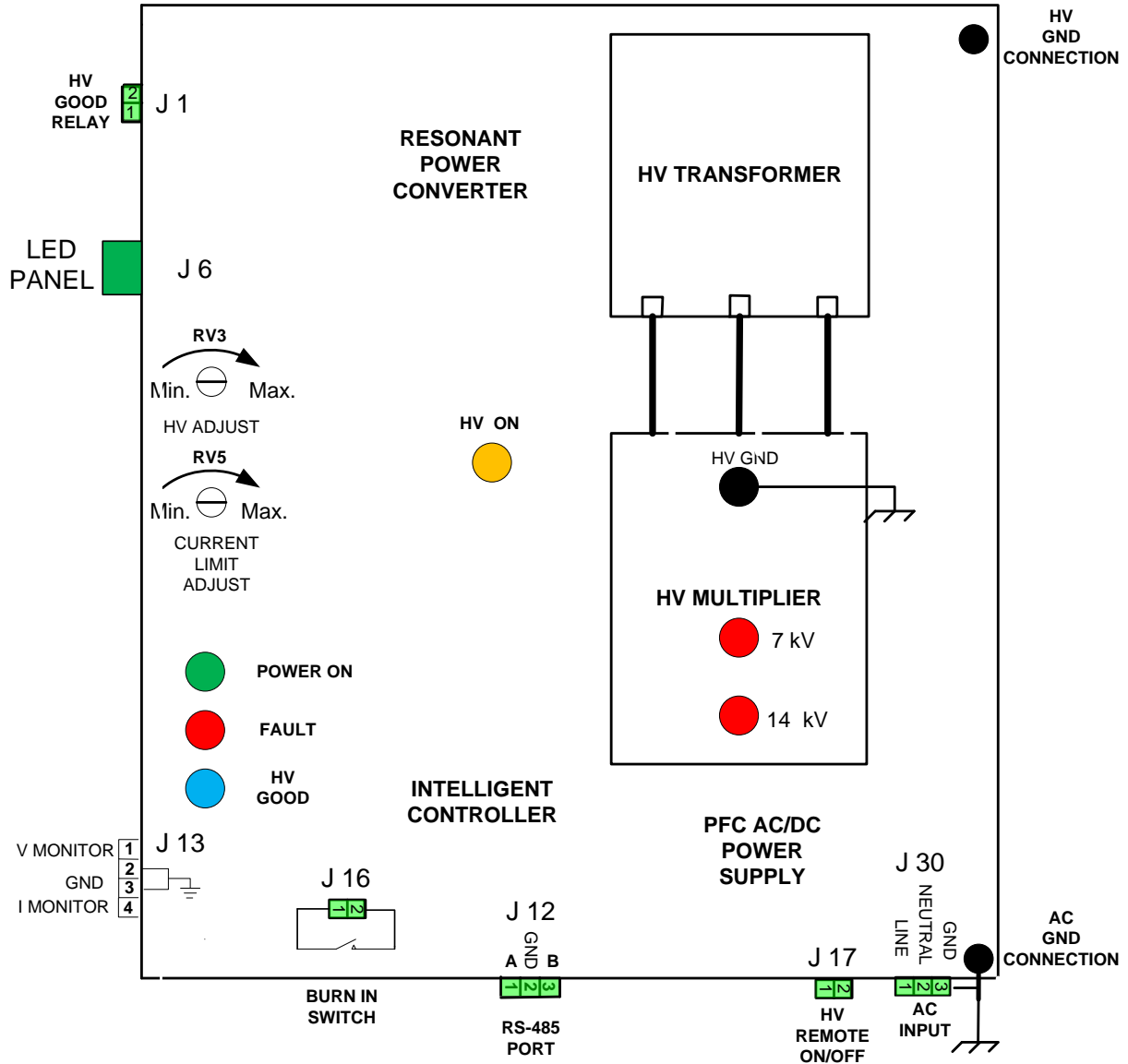

Fig.2 Connections, Indicators and Controls

4.0 Field wiring connections

These instructions are for qualified personnel only. To reduce the risk of electric shock, do not perform any servicing other than contained in the instructions unless you are qualified to do so. All wiring must be installed according to national, state and local codes.

The HV Power Supply requires the following field connections shown in Fig.2

1. AC line connection (main input) including safety GND (J3, highlighted in green)
2. HV Connection to cells (7kV and 14kV terminal studs, highlighted in red)
3. HV Relay status contacts (J1, highlighted in green)
4. RS-485 / Modbus communication port (J12, highlighted in green)
5. HV GND from the cells to be connected to ground terminal on the enclosure which is connected to the aluminum plate and PCB board (AC GND connection point) - connection point is located at the PCB corner which provide connection to mounting chassis by mounting screw.
6. Remote start ON/OFF terminals J17 highlighted in green (To turn HV converter ON - dry contact closure is needed)
7. Remote diagnostic LED panel connected to RJ45 type connector J6 on the Main Board (highlighted in green)
8. Remote momentary push button located on front face of enclosure (burn in function) connected via two wires to J2 (highlighted in green)
9. Optional Voltage and current Monitor (J13)

5. Start - up

WARNING!!! HIGH VOLTAGE - RISK OF ELECTRIC SHOCK

Check load cells specifications and number of cells connected before adjusting the HV and current limits. Instructions below are to operate the HV Power supply in Voltage Source Mode. Consult factory if Current Source Mode is preferred.

1. Turn the HV Adjust trim pot RV3 to the minimum (fully CCW position) and Current Limit trim pot RV5 to the maximum (Fully CW position)
2. Turn AC power on. (Closure of dry contact is expected)

WARNING: If Remote start ON/OFF terminal block dry contacts are closed, HV comes on as soon as main AC power is applied.

Power On LED (Green) should turn On. At this stage only main power is ON and MCU monitors and reports status of the HV converter.

3. Dry contact closure is expected on remote start ON Off terminal block J5 contacts to turn HV converter ON
4. Adjust slowly HV by turning the trim pot RV3 clockwise until HV Good LED (Blue) turns On and output current reaches required value.
5. Fault LED (Red) should stay Off. If Fault LED comes on – please refer to the instructions in Service/troubleshooting manual.

Output current adjustment is based on the type and number of load cells connected to the HV supply. Typical settings are 1mA per cubic foot of load cell.

To facilitate installation and initial adjustment the HV and load current can be monitored on PC running any ASCII data terminal or Lab View application.

This concludes powering up/adjusting the HV power supply.

6. Specifications

1. Power Input:

- a. Voltage: Universal voltage input 120 – 240VAC
- b. Current: 2A @ 120VAC, 1 Amp at 240VAC
- c. Frequency: 50/60HZ
- d. Power: < 250W
- e. Power Factor : > 0.90
- f. Operating efficiency: 82% typical

2. HV Output:

- a. Voltage: IONIZER adjustable 7.0 to 14.0 kV DC
COLLECTOR adjustable 3.5 to 7.0kV DC
- b. Current: 12mA max at 14kV
Current limit adjustable 1mA to 12mA

3. Temperature:

Operating: 0 to 50 deg C

Storage: -40 to +80 deg C

4. Overload/Fault protection

- a. Automatic shut down when load current exceeds 12mA load at 14KVDC.
Automatic and soft restart when overload condition is removed.
- b. Fast control loop (Fast Clamp) keeps the output below 15kV when HV load is disconnected and when main regulation loop fails.

c. Voltage and Current Faults

- d. The recovery from fault condition caused by voltage or current outside the operating window is monitored and timed by two fault counters - Fault Counter 1 and Fault Counter 2. Refer to protection flow chart.
- e. When voltage or current or overload fault happens, unit restarts automatically after 2 sec delay and displays error message. The internal Fault Counter 1 is incremented. After 10 restarts, HV shuts down for 1 min, Fault Counter # 2 is incremented, and Fault Counter # 1 is cleared.
This process may repeat 5 times (until Fault Counter 2 content exceeds 3) and then the HV is turned off permanently.
So, the unit allows $5 \times 10 = 50$ faults with 2 sec recovery time after each fault and additional 1 min recovery after every 10 faults.
After 50 times, unit shuts down permanently.
To restart the unit from the permanent shutdown condition input AC power must be recycled.

7.0 Intelligent Controller

Microcontroller based, comprising status LED and optional communication port

- Monitors output current, HV
- Counts hours of operation
- Optional Isolated RS-485 or Modbus port outputs Voltage, Current, Hours of operation, Faults alerts.

Status LEDs functionality and serial data format is shown in the Appendix A.

Safety features

- HV ON warning LED
- Dry contacts to signal HV GOOD (contacts closed when HV within operating window)

8.0 Connectivity

a. Inputs:

120V to 240VAC, Live and Neutral on terminal strip J30, Earth Ground, #6 Lug on chassis

Remote start ON/OFF terminals J17. Relay coil sourcing 12V, 20mA dry contact closure to turn HV On.

b. OUTPUTS:

- Ionizer Voltage, Collector Voltage - # 10 Lugs on # 10 studs.
- High Voltage Return - # 6 Lug on chassis
- 250VAC/10Amp dry contacts J1 to indicate HV GOOD condition
- Isolated RS-485 or Modbus port J12 (see Appendix A)
- Voltage and current Monitor connector J13 (see Appendix A)

c. INDICATORS: On Controller PCB and remote PCB

LED Blue Indicator: HV Good (for remote LED terminal)

LED Green Indicator: Input Power On

LED Yellow Indicator: HV ON

LED RED Indicator: FAULTS

The complete functionality of LED indicators and Relay output logic is shown in Appendix A, Table 1

9.0 Mechanical Specifications

All PCB electrical & components must be mounted in custom metal enclosure with fan on one side and ventilation levers on other side to create air circulations inside the box.

The PS PCB must be mounted in the enclosure with min of 2" distance from metal surface on all sides.

PCB's dimensions 8" W x 10" L x 4" H

10.0 Agency Approvals

cURus

11.0 Manufacturer's Marking:

P/N, Date code, serial #

Appendix A

1.0 LED and Relay Logic

#	System Status	BLUE LED - HV Good,	GREEN LED - AC Supply is ON	RED LED FAULT	YELLOW LED HV ON	AC ON/OFF terminals
1	Standby	OFF	ON	OFF	OFF	Open
2	System Good	ON	ON	OFF	ON	Shorted
3	Burn in	ON	ON	Quick blink	ON	Shorted
4	Overload fault	OFF	ON	2 Flashes & pause	ON	Shorted
5	Over voltage fault	OFF	ON	3 Flashes & pause	OFF	Shorted
6	System shutdown for 10min due to continuous arcing below 10KV.	OFF	ON	OFF	OFF	Shorted

Table1. LED Indicators and Relay output logic

2.0 RS-485 and Modbus specifications/protocol

RS-485 / Modbus is available on J12 terminal block

J12-1 TX

J12-2 GND

J12-3 RX

System Parameters for MODBUS 14KV, 40mA, 12mA, 6mA

	Modbus system parameters	Value
1	Speed	3
2	Data bits	8
3	Parity	0
4	Stop Bits	1
5	MCU address - default	3

	Full parameter name	Type	Type	Function 6 (write) Modbus address
1	Software revision number		Write/read	1
2	Operation hours(hrs) low	0~9999 hours	read(only)	2
	Operation hours(hrs) high	10000~250000 hours	read(only)	3
3	Overload alarm counter		read(only)	4
4	Undervoltage alarm counter		read(only)	5
5	Output voltage – V out (KV)	40mA = 0.0166v/ 12mA= 0.01639*V	read(only)	6
6	Output Current - I out (mA)	40mA=0.0465*I / 12mA=0.01395*I	read(only)	7
7	Spare		read(only)	8
8	Burning in status	Turn - Burning on/off	Write/read	9
9	Overvoltage alarm counter		read(only)	10
10	High output voltage ON/OFF	High voltage ON status	read(only)	11.4
11	Voltage high alarm		read(only)	11.0
12	Voltage low alarm		read(only)	11.1
13	Current high alarm		read(only)	11.2
14	Temperature high alarm		read(only)	11.3
15	Overload Alarm Counter	(Arcing Overload) 50 times shut down		11.5
16	Power supply common alarm		read(only)	11.6
17	Power Supply power 120-240V status	Signal to turn on/off HVPS (Dry Contact)	read(only)	11.7
18	MCU Modbus address		Write/read	12
19	Overcurrent alarm counter		read(only)	13
20	Burning in counter	3 hours count down	read(only)	14
21	Operational working minute(burning)		read(only)	15
22	Operational working seconds (burning)		read(only)	16

3.0 Voltage and Current Monitor

06/27/2022

High Voltage and current monitor signals are available on connector J13

Monitoring signals have been scaled for easy readings:

- Voltage monitor 100mV/kV
- Current Monitor 100mV/mA

The location of monitoring connector and pin out is shown in Fig.3

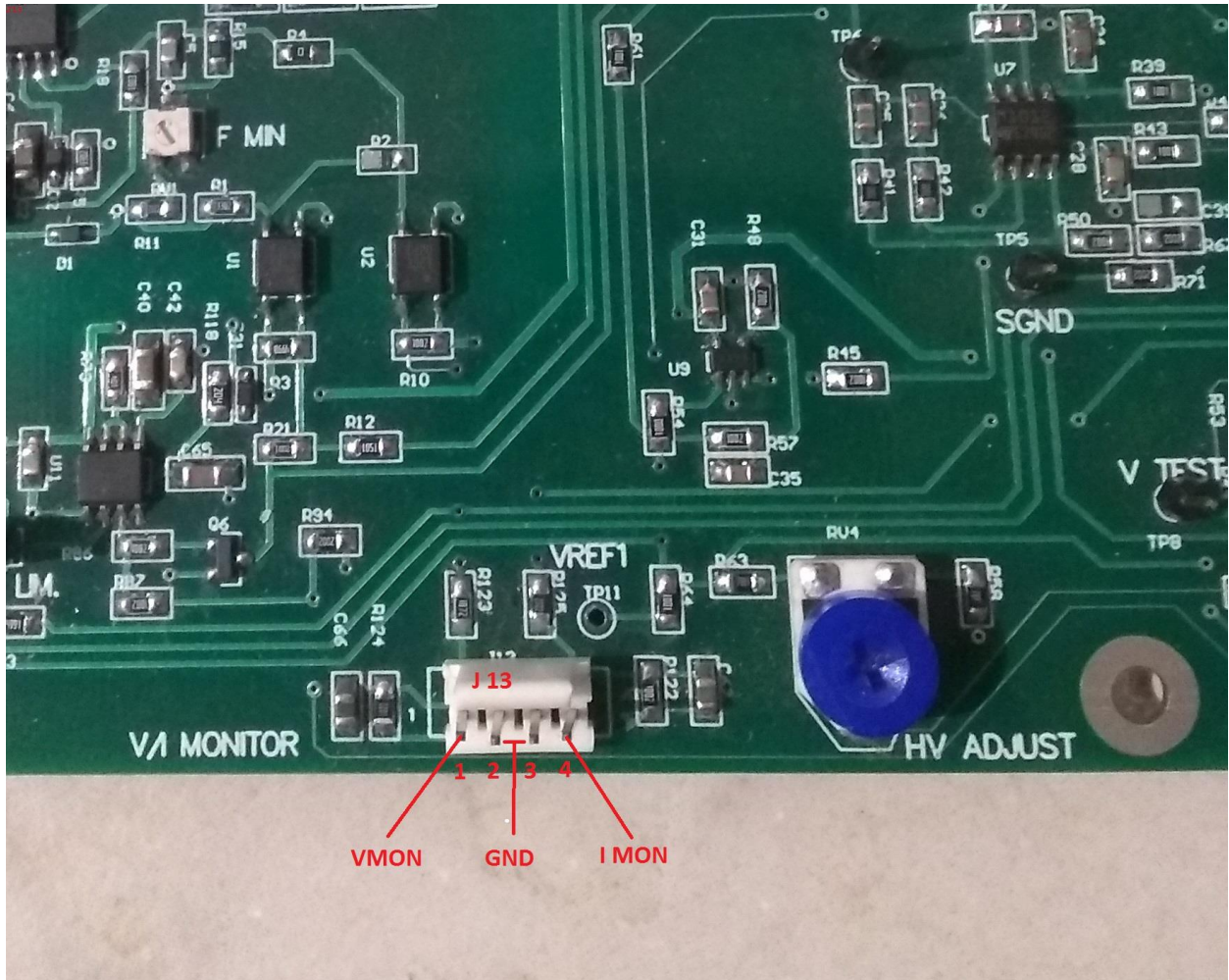

Fig.3 V/I Monitor connector

J13 connector pin out

1 – Voltage Monitor

2- GND

3- GND

4- Current Monitor

J13 connector header is AMP MTA 100 type.

The mating plug part # is 640621-4

<https://www.digikey.ca/en/products/detail/te-connectivity-amp-connectors/640621-4/258814>