



Addressable Pre-programmed Controller

ACL-ADPPC Wiring Diagram



Please Note:

This wiring diagram is provided for reference purposes only and is not specific to any one project.

It illustrates general wiring configurations.

Actual components, modules, power supplies, cable types, and distances may vary depending on project size and site conditions.

All pre-programming is completed by Allanson's ColorMix Technical Support team.

For maximum loading capacity and compatible power supplies, please refer to the Addressable RGB product specification sheets.

For additional details, consult the relevant product accessories and components specification sheets.

For any inquiries, please contact your regional Allanson sales manager.



Addressable Pre-programmed Controller

ACL-ADPPC Wiring Diagram



Scenario #2: Direct Connection

Apply power supply to the string of modules based on max loading recommendation.

Follow the directional arrows on the modules to ensure correct wiring orientation.

ACL-ADPPC

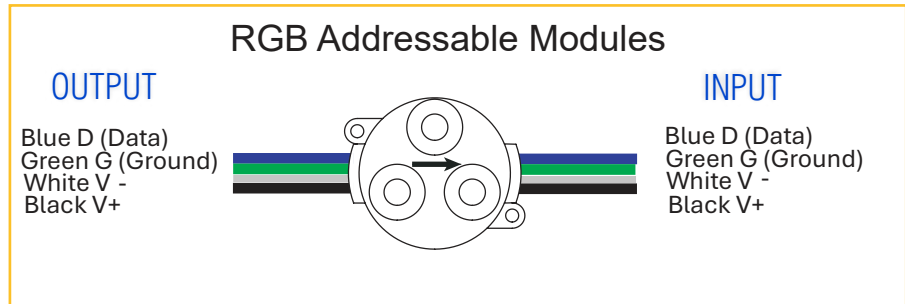
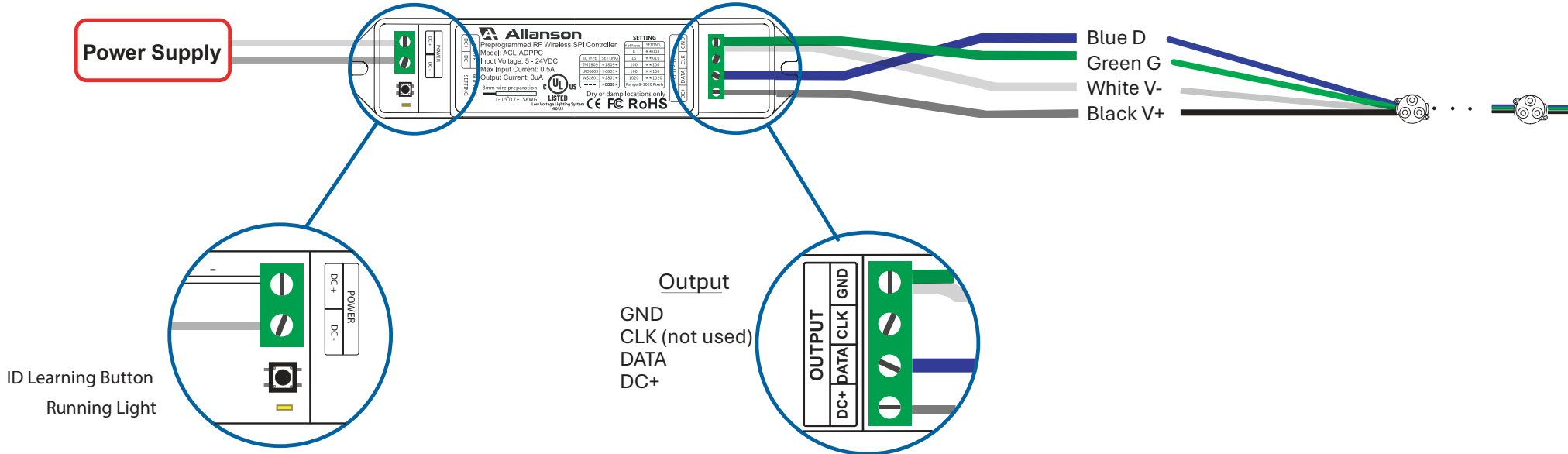

Scenario #2: Via Cat 5/6 Cable

Apply power supply to the string of modules based on max loading recommendation.
Follow the directional arrows on the modules to ensure correct wiring orientation.

