



## ELECTRONIC IGNITOR INSTRUCTION MANUAL - TYPE 2280U / 2280-XXX

This instruction manual provides you with application information on the OMNI™ Electronic Ignitor. Allanson's electronic ignitors are designed for **intermittent duty (constant)** and/or **interrupted duty** - providing the most reliable ignition source for gas and oil.

### Abosolute Minimum Readings:

Input Supply Voltage (V):	216-252
Input Supply Frequency (Hz):	50/60
Primary Volt - Amperes (VA)	87
Secondary Voltage (kV peak):	17.5
Secondary Frequency (kHz):	>20
Secondary Short Circuit Current (mA):	28
Storage Temperature:	-40 to +80
Operating Temperature:	-30 to +40
Operating Relative Humidity (%):	90
Loading Air Gap (inches):	1/16 to 3/16

### Mechanical Specifications:

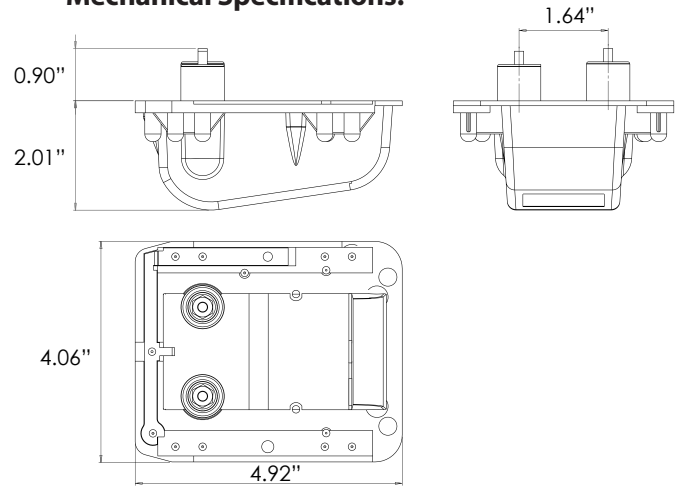

**CANADA:** 83 Commerce Valley Drive East, Markham, Ontario L3T 7T3 | T: 1.800.661.7251 | Fax: 416.752.6717  
**USA:** 99 Adams Blvd., Farmingdale, New York 11735 | T: 1.631.293.3880 | Fax: 1.631.293.3470



## ELECTRONIC IGNITOR INSTRUCTION MANUAL - TYPE 2280U / 2280-XXX

This instruction manual provides you with application information on the OMNI™ Electronic Ignitor. Allanson's electronic ignitors are designed for **intermittent duty (constant)** and/or **interrupted duty** - providing the most reliable ignition source for gas and oil.

### Abosolute Minimum Readings:

Input Supply Voltage (V):	216-252
Input Supply Frequency (Hz):	50/60
Primary Volt - Amperes (VA)	87
Secondary Voltage (kV peak):	17.5
Secondary Frequency (kHz):	>20
Secondary Short Circuit Current (mA):	28
Storage Temperature:	-40 to +80
Operating Temperature:	-30 to +40
Operating Relative Humidity (%):	90
Loading Air Gap (inches):	1/16 to 3/16

### Mechanical Specifications:

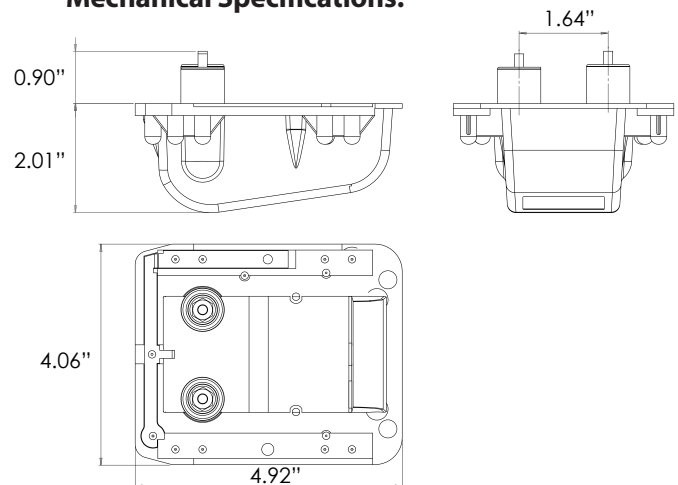

**CANADA:** 83 Commerce Valley Drive East, Markham, Ontario L3T 7T3 | T: 1.800.661.7251 | Fax: 416.752.6717  
**USA:** 99 Adams Blvd., Farmingdale, New York 11735 | T: 1.631.293.3880 | Fax: 1.631.293.3470

## Installation:

1. Before installation, inspect the case and the porcelain bushings for possible damage during transportation and handling. Do not use the product if the secondary bushings are chipped and/or cracked.
2. Choose the correct base plate from the kit (if provided) to fit the burner. Route the primary lead wires to the appropriate lead exit on the base plate and fasten the electronic ignitor to this plate with the three self-tapping screws provided.
3. Install the electronic ignitor assembly on the burner and route the primary leads to the junction box for connection. **Connect the black lead to the negative terminal (-) and the red lead to the positive terminal (+) of the supplies.** (*Reversing the lead connection will result in the unit not operating properly*). Use only UL Listed and CSA approved wire nuts.

## Maintenance:

The OMNI® Electronic Ignitor has no moving parts. The only maintenance required is the cleaning of the porcelain bushings with a soft cloth during the annual furnace inspection.

## Testing:

### WARNING

**This procedure is to be carried out by qualified personnel ONLY.**

**The voltages and currents available can cause serious injury and/or death. Extreme caution is to be used to avoid contact with the primary live leads. Do not allow any parts of your body to come closer than 5 inches to the energized secondary terminals or parts of the secondary circuit. Ensure the mid-point of the transformer is grounded before energizing the primary.**

The OMNI® 2280U / 2280-XXX Electronic Ignitor can be tested as follows to ensure that it is operating properly.

**Chek-Mate™ (Allanson's Ignitor/Transformer tester).** Use it to touch any brand of ignitor/transformer. Simply touch the high voltage spheres to the high voltage contacts. If the green LED lights up, the unit is performing well.

**Short Circuit Current Test.** Connect a true RMS high frequency milliammeter to the output terminals. Energize the primary with 240 Volts at 50/60 Hz. The reading on the milliammeter should be within 10% of the rated.

**Open Circuit Test.** For this test you need an oscilloscope and a high voltage oscilloscope probe. Connect the high voltage probe from one secondary to the ground terminal (screw in front and between the high voltage bushings). Measure the peak of the wave form on the oscilloscope. Repeat the procedure for the opposite high voltage terminal. The sum of the two readings should be within 10% of the name plate rating.

**Field Testing.** Connect the electronic ignitor grounding terminal to a good ground. Connect the primary leads of the electronic ignitor to 240 Volts. Energize the primary. Holding the handle of a well insulated screw driver, touch one part of the shaft of the screw driver to one high voltage terminal. Pivot on this terminal until you draw an arc from the opposite terminal. Gradually increase the air gap and notice the distance at which the arc is extinguished. The minimum distance should be 1/2".

For more information please visit us at [allanson.com](http://allanson.com) or contact us at [cservice@allanson.com](mailto:cservice@allanson.com).

## Installation:

1. Before installation, inspect the case and the porcelain bushings for possible damage during transportation and handling. Do not use the product if the secondary bushings are chipped and/or cracked.
2. Choose the correct base plate from the kit (if provided) to fit the burner. Route the primary lead wires to the appropriate lead exit on the base plate and fasten the electronic ignitor to this plate with the three self-tapping screws provided.
3. Install the electronic ignitor assembly on the burner and route the primary leads to the junction box for connection. **Connect the black lead to the negative terminal (-) and the red lead to the positive terminal (+) of the supplies.** (*Reversing the lead connection will result in the unit not operating properly*). Use only UL Listed and CSA approved wire nuts.

## Maintenance:

The OMNI® Electronic Ignitor has no moving parts. The only maintenance required is the cleaning of the porcelain bushings with a soft cloth during the annual furnace inspection.

## Testing:

### WARNING

**This procedure is to be carried out by qualified personnel ONLY.**

**The voltages and currents available can cause serious injury and/or death. Extreme caution is to be used to avoid contact with the primary live leads. Do not allow any parts of your body to come closer than 5 inches to the energized secondary terminals or parts of the secondary circuit. Ensure the mid-point of the transformer is grounded before energizing the primary.**

The OMNI® 2280U / 2280-XXX Electronic Ignitor can be tested as follows to ensure that it is operating properly.

**Chek-Mate™ (Allanson's Ignitor/Transformer tester).** Use it to touch any brand of ignitor/transformer. Simply touch the high voltage spheres to the high voltage contacts. If the green LED lights up, the unit is performing well.

**Short Circuit Current Test.** Connect a true RMS high frequency milliammeter to the output terminals. Energize the primary with 240 Volts at 50/60 Hz. The reading on the milliammeter should be within 10% of the rated.

**Open Circuit Test.** For this test you need an oscilloscope and a high voltage oscilloscope probe. Connect the high voltage probe from one secondary to the ground terminal (screw in front and between the high voltage bushings). Measure the peak of the wave form on the oscilloscope. Repeat the procedure for the opposite high voltage terminal. The sum of the two readings should be within 10% of the name plate rating.

**Field Testing.** Connect the electronic ignitor grounding terminal to a good ground. Connect the primary leads of the electronic ignitor to 240 Volts. Energize the primary. Holding the handle of a well insulated screw driver, touch one part of the shaft of the screw driver to one high voltage terminal. Pivot on this terminal until you draw an arc from the opposite terminal. Gradually increase the air gap and notice the distance at which the arc is extinguished. The minimum distance should be 1/2".

For more information please visit us at [allanson.com](http://allanson.com) or contact us at [cservice@allanson.com](mailto:cservice@allanson.com).