



ELECTRONIC IGNITORS

INSTRUCTION MANUAL for MODELS: 2260-TP, 2260-TW, 2260-P, 2260-TPLP, & 2260-TWLP

1. Introduction

This instruction manual provides you with application information on the 2260 series of electronic ignitors. These devices are designed for **CONSTANT DUTY** and provide the most reliable ignition source for commercial/industrial gas applications. **Before proceeding identify the model you are installing by the mechanical specifications on reverse side.**

2. Absolute Maximum Ratings

Input Supply Voltage (V):	108 to 132
Input Supply Frequency (Hz):	50/60
Primary Volt - Amperes (VA):	72
Secondary Voltage (kV peak):	15.6
Secondary Frequency (kHz):	>20
Secondary Short Circuit Current (mA):	28
Storage Temperature (°C):	-40 to +80
Operating Temperature (°C):	-30 to +40
Operating Relative Humidity (%):	90
Loading Air Gap (inches):	1/16 - 3/16

3. Installation

a) Install the ignitor assembly on the burner and route the primary leads to the junction box or control panel for connection.

Primary cord sets: Models 2260-TP, 2260-P, 2260-TPLP, and 2260-TWLP are shipped with primary plug set. Model 2260-TW has traditional bottom exit pigtailed and optional knockouts on case bottom for routing of primary wire to junction box.

Mounting: Model 2260-P is mounted through the case and via ground tab. Models 2260-TW, 2260-TP, 2260-TPLP and 2260-TWLP are mounted using the ears/tabs on side of case.

Connect leads as required by wiring method described in control instruction manual or by specific application requirements.

4. Maintenance

These ignitors have no moving parts. The only maintenance required is the cleaning of the primary and secondary connections with a soft cloth during the annual system inspection.

5. Testing

WARNING

This procedure is to be carried out by qualified personnel ONLY.

The voltages and currents available can cause serious injury and/or death. Extreme caution is to be used to avoid contact with the primary live leads. Do not allow any parts of your body to come closer than 5 inches to the energized secondary terminals or parts of the secondary circuit. Ensure the transformer is grounded before energizing the primary.

The 2260 Ignitors can be tested as follows to ensure that they are operating properly.

a) **Short Circuit Current Test.**

Route one connection on a true RMS high frequency milliammeter to the output terminal and the second connection to ground. Energize the primary with 120 Volts at 50/60 Hz. The reading on the milliammeter should be within -15% +10% of the rated.

b) **Field Testing.**

Allanson's Chek-Mate™ Ignitor / Transformer Tester can be used to test the 15kVpk Ignitor. You will require a set of 2 alligator clips - order Allanson's Chek-Mate accessory kit part #SC-2200-Kit. Ensure unit is grounded and powered OFF before proceeding. Jump out oper. controls or thermostat/aquastat. Route 1 alligator clip from sphere on Chek-Mate to secondary wire, and second alligator clip to run from sphere on Chek-Mate to ground. Power on burner and if green led lights (no more than 3 seconds) unit is good.

6. Mechanical Specifications Model 2260-TW, 2260-TP

2260-TP

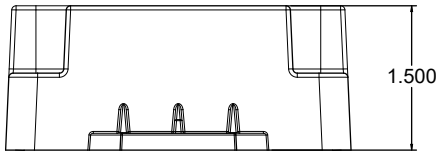

2260-TW

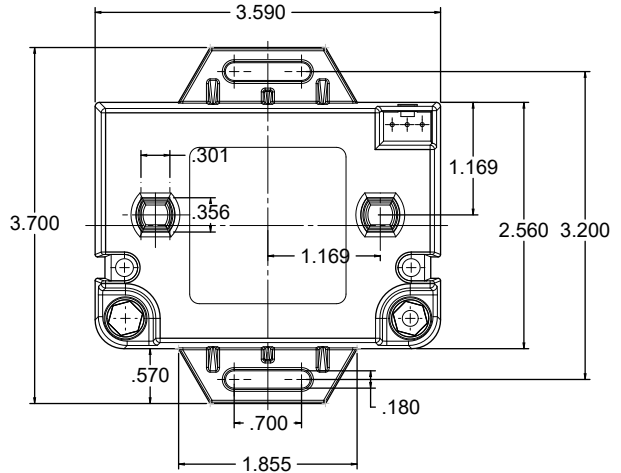
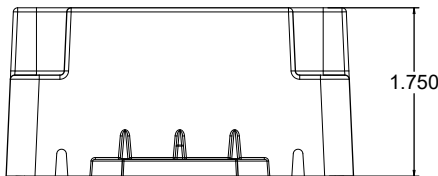

7. Mechanical Specifications Model 2260-P

2260-P

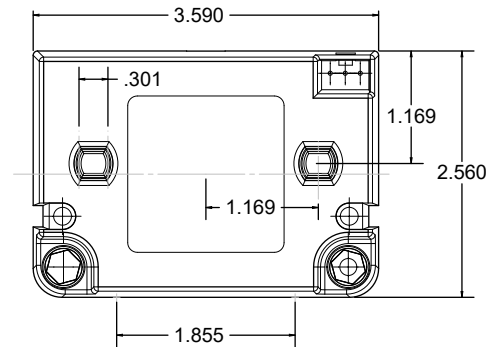
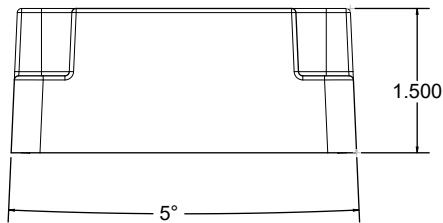

8. Mechanical Specifications Model 2260-TPLP & 2260-TWLP

2260-TPLP & 2260-TWLP

